

TROLLEYS (GEARED TROLLEY & PLAIN TROLLEY)

0.5 ton to 10 ton for Chain hoist

HOOK SUSPENSION TYPE

The chain hoist and trolley can be connected simply by inserting the top hook into the hole of the trolley suspension plate. The most suitable wheels and wheel pitches give the trolleys exceptionally small minimum curve radii.

We also manufacture trolleys for 10 ton and larger capacities, please ask your dealer for further information.

COMBINATION WHEELS FOR I & H-BEAMS

The 0.5 to 5 ton trolleys are equipped with I & H-Beam combination wheels that will run smoothly on either flat or taper beams.

CONVENIENT ADJUSTABILITY

The trolley can be adjusted to 3-different beam widths with the adjusting collars. Non-standard beam widths are also available.

GEARED TROLLEY (GT-5)

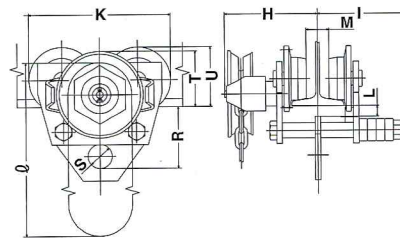
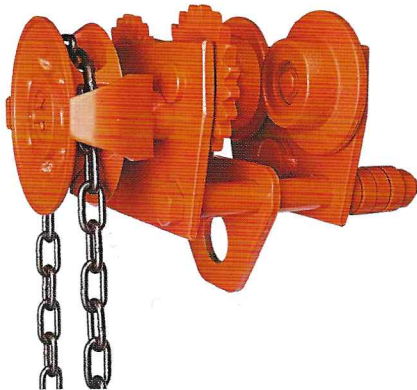

GT-5 Diagrammatic only

PLAIN TROLLEY (PT-5)

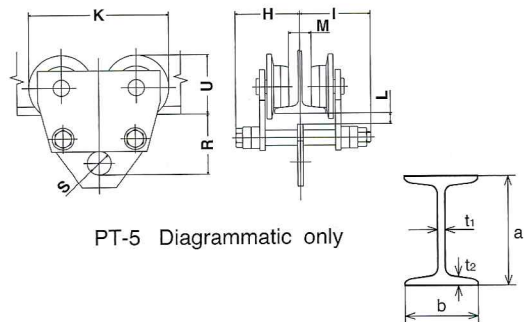
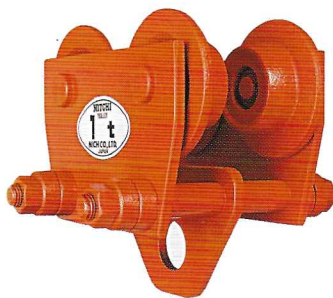

PT-5 Diagrammatic only

STANDARD SPECIFICATIONS: GT-5 Geared Trolley & PT-5 Plain Trolley

Item No.	Geared Trolley (GT-5) & Plain Trolley (PT-5)										Geared Trolley (GT-5)				Plain Trolley (PT-5)				
	Rated load (ton)	Standard I-Beam (mm) a×b×t1	Minimum radius for curve (mm)	Test load (ton)	Major Dimensions (mm)						Lift (m)	Net weight (kg)		Major Dimensions (mm)		Net weight (kg)	Major Dimensions (mm)		
					K	L	M	R	S	U		H	I	T	Ø		H	I	
GT5005 PT5005	0.5	125×75×5.5 180×100×6 250×125×7.5	800	0.75	195	23-t2	b-43	94-t2	32	72+t2	2.5	9	b/2 +73	168 -b/2	96+t2	2.5	6	93	105
GT5010 PT5010	1	150×75×5.5 180×100×6 250×125×7.5	1,000	1.5	206	25-t2	b-42	99-t2	35	78+t2		12	b/2 +98	168 -b/2	72+t2	2.5	8	95	103
GT5015 PT5015	1.6	150×75×5.5 180×100×6 250×125×7.5	1,100	2.4	221	32-t2	b-41	108-t2	40	85+t2		15	b/2 +98	174 -b/2	72+t2	2.5	11	112	112
GT5020 PT5020	2	200×100×7 250×125×7.5 300×150×8	1,200	3.0	262	31-t2	b-63	130-t2	45	102+t2	3.0	23	b/2 +108	203 -b/2	115+t2	3.0	17	128	128
GT5030 PT5030	3.2	200×100×7 250×125×10 300×150×11.5	1,500	4.8	306	32-t2	b-63	130-t2	56	126+t2		32	b/2 +108	208 -b/2	119+t2	3.0	26	133	133
GT5050 PT5050	5	250×125×10 300×150×11.5 450×175×11	1,500	7.5	329	37-t2	b-76	152-t2	65	132+t2		52	b/2 +141	253 -b/2	128+t2	3.0	45	166	166
GT5100	10	400×150×12.5 450×175×13	3,000	12.5	420	45-t2	b-84	235-t2	80	175+t2	3.5	115	b/2 +189	b/2 +104	184+t2	3.5	-	-	-

N.B. 1. The table shows the standard lifts. Other chain lengths are also available.
2. PT-5 Plain Trolley is only available up to 5 ton.

The design, materials and specifications are subject to change for improvements without notice.