

# NITCHI-MATIC ELECTRIC CHAIN HOIST WITH ELECTRIC TROLLEY

## MODEL EMT-MH-5

In addition to hoisting and lowering, Model EMT-MH-5 (1-speed hoist with 1-speed trolley) can transport heavy loads swiftly with great efficiency and complete safety. 0.5 ton to 7.5 ton trolleys can be adjusted to fit the different beam sizes listed in the table by simple relocation of the spacing washers to the inside or to the outside of the frame.

The drop-forged steel trolley wheels are heat-treated and have precision bearings to provide smooth and easy travel.

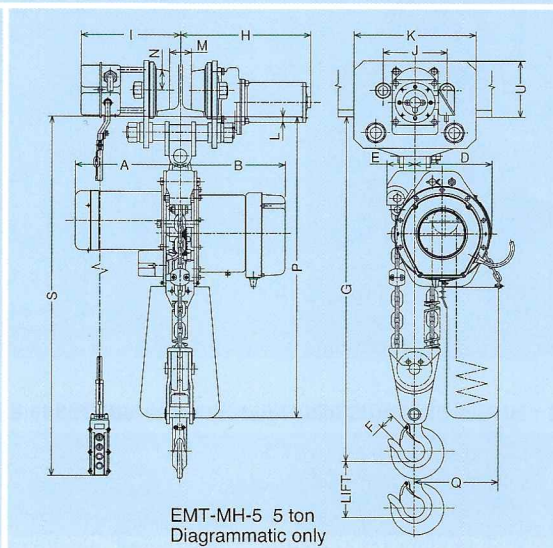
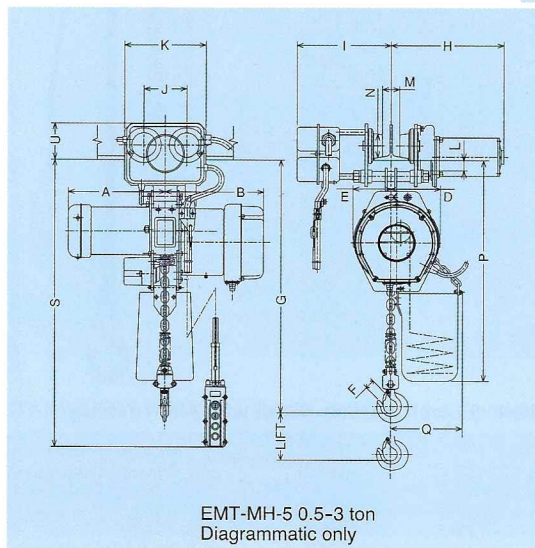
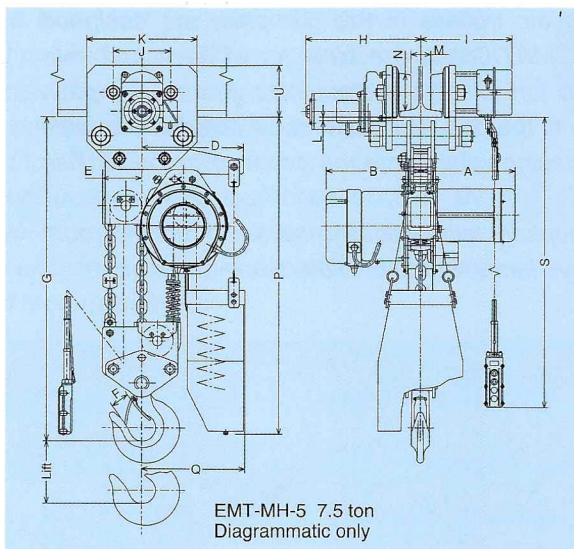

### STANDARD SPECIFICATIONS : EMT-MH-5 Electric Chain Hoist with Electric Trolley

Item No.	Rated Load (ton)	Lift (m)	Hoist Motor						Traversing Speed(m/min)		Trolley Motor					Test Load (ton)	Minimum Headroom (Max.) G (mm)	Net Weight ※ (approx.) (≒kg)		
			Hoisting Speed (m/min)		3-phase Output(kW)		Ins. Class	Rating (min)	Load Chain Dia. (mm)	Nos. of falls	3-phase			Minimum radius for curve (m)						
			50Hz	60Hz	50Hz	60Hz					Output (kW)	Ins. Class	Rating (min)		Breadth of Beams b (mm)					
MHE5005	0.5	4.0	8.6	10.0	0.83	1.0	B	30	7.1	1	20(10)	24(12)	0.2	E	30	75, 100, 125	1.0	0.625	535	84
MHE5010	1		6.2	7.3	1.17	1.4			7.1	1	20(10)	24(12)	0.2			75, 100, 125	1.0	1.25	545	86
MHE5020	2		6.7	7.9	2.5	3.0			11.2	1	20(10)	24(12)	0.4			100, 125, 150	1.0	2.5	725	153
MHE5030	3		4.4	5.2	2.5	3.0			11.2	1	20(10)	24(12)	0.4			100, 125, 150	1.5	3.75	805	172
MHE5050	5		2.6	3.1	2.5	3.0			11.2	2	10(20)	12(24)	0.4(0.75)			125, 150, 175	1.5	6.25	975	219
MHE5075	7.5		1.7	2.1	2.5	3.0			11.2	3	10	12	0.75			150, 175	1.5	9.37	1,065	290

Item No.	Rated Load (ton)	Major Dimension (approx.) (mm)															
		A	B	D	E	F	H	I	J	K	L	M	N	U	※P	※Q	S (m)
MHE5005	0.5	265	285	152	106	20	b/2+280	b/2+230	127	240	32-t <sub>2</sub>	b-49	φ69	99+t <sub>2</sub>	675	220	4.0
MHE5010	1	285	285	152	106	25	b/2+280	b/2+230	127	240	32-t <sub>2</sub>	b-49	φ69	99+t <sub>2</sub>	675	220	4.0
MHE5020	2	335	335	195	127	30	b/2+325	b/2+235	159	300	33-t <sub>2</sub>	b-70	φ95	121+t <sub>2</sub>	860	235	4.0
MHE5030	3	335	335	195	127	36	b/2+330	b/2+240	180	340	37-t <sub>2</sub>	b-76	φ110	134+t <sub>2</sub>	920	290	4.0
MHE5050	5	335	335	247	93	43	b/2+330	b/2+245	204	390	38-t <sub>2</sub>	b-80	φ130	158+t <sub>2</sub>	1,010	400	4.0
MHE5075	7.5	335	335	360	145	65	b/2+330	b/2+250	204	390	38-t <sub>2</sub>	b-80	φ130	158+t <sub>2</sub>	1,140	400	4.3

e - The values in the ( ) are for electric trolleys with half speed and special speed.  
 f - The dimensions P and Q marked \* in the above table vary according to different lifts.  
 g - With each hoist is packed a handbook giving comprehensive instructions for installation, and operation with an inspection certificate.

The design, materials and specifications are subject to change for improvements without notice.