

NITCHI-MATIC ELECTRIC CHAIN HOIST

MODEL MH-5

The single load chain fall design of 3 ton and the exceptionally low headrooms of Model MH-5 are the results of the streamlined, robust steel constructions and well balanced designs.

Model MH-5 1-speed hoist is available in a wide range of standard capacities for your choice..... available from light 0.5 ton loads to extremely heavy 50 ton loads. Please refer to succeeding page for specifications of 10 ton and larger capacities.

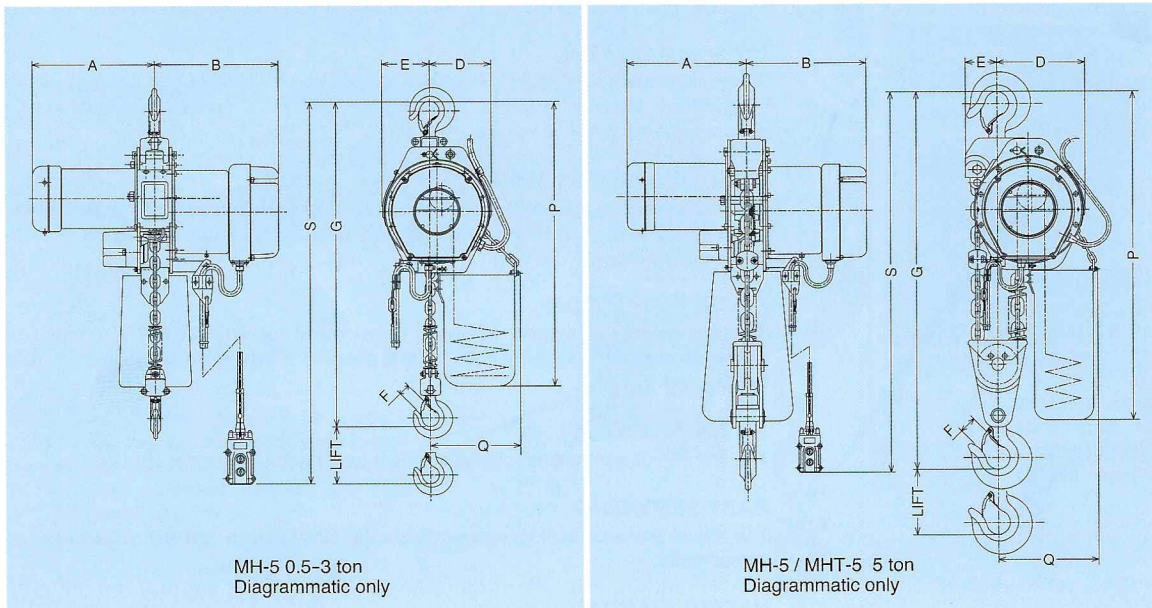
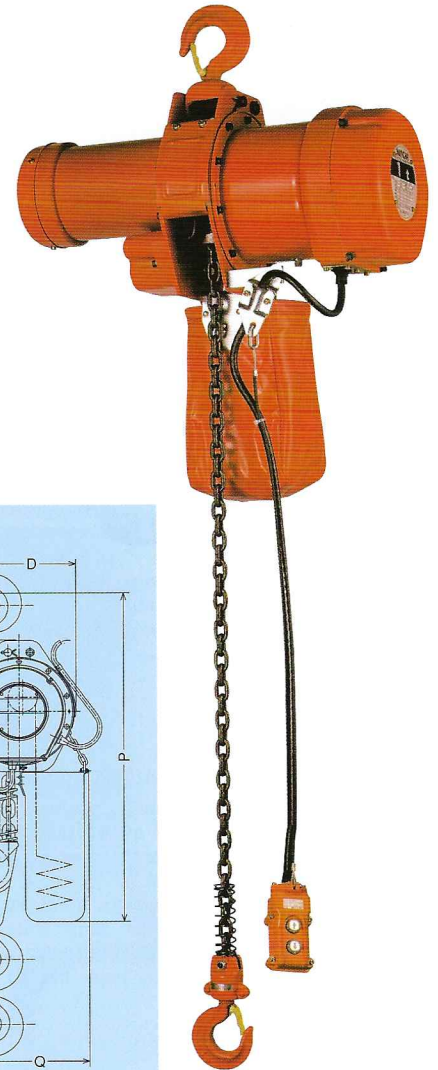

STANDARD SPECIFICATIONS : MH-5 Electric Chain Hoist

Item No.	Rated Load (ton)	Lift (m)	Hoisting Speed(m/min)		Hoist Motor 3-phase					Load Chain		Test Load (ton)	Minimum Headroom (Max.) G (mm)	Net Weight ※ (approx.) (±kg)	Grade
			50Hz	60Hz	Output(kW)		Ins. Class	Rating (min)	% ED	Dia. (mm)	Nos.of falls				
					50Hz	60Hz									
MH5005	0.5	4.0	8.6	10.0	0.83	1.0	B	30	40	7.1	1	0.625	550	53	M5
MH5010	1		6.2	7.3	1.17	1.4				7.1	1	1.25	560	55	M4
MH5020	2		6.7	7.9	2.5	3.0				11.2	1	2.5	725	100	M5
MH5030	3		4.4	5.2	2.5	3.0				11.2	1	3.75	765	102	M4
MH5050	5		2.6	3.1	2.5	3.0				11.2	2	6.25	925	130	M4

Item No.	Rated Load (ton)	Major Dimensions (approx.) (mm)							
		A	B	D	E	F	※P	※Q	S(m)
MH5005	0.5	265	285	152	106	20	690	220	3.6
MH5010	1	285	285	152	106	25	690	220	3.6
MH5020	2	335	335	195	127	30	860	235	3.8
MH5030	3	335	335	195	127	36	880	235	3.8
MH5050	5	335	335	247	93	43	960	290	3.8

- NOTES:**
- a - Only the standard lifts hoists, are enumerated above. Please apply for extra long lifts.
 - b - Please state power source voltage and Herz on enquiry and or ordering.
 - c - 4-core colored cords with rubber-covered power source cable is supplied, without plug.
 - d - A chain collecting bucket is supplied with each hoist as standard attachment.